

<b>Engine</b>	Cummins 6LTAA8.9
<b>Gross Power</b>	221 kW (300 hp) @ 2,000 rpm
<b>Net Power</b>	210 kW (285 hp) @ 2,000 rpm
<b>Operating Weight</b>	23,950 kg
<b>Standard Bucket Size</b>	4.2 m <sup>3</sup>
<b>Standard Breakout Force</b>	200 kN
<b>Standard Dump Clearance</b>	3,150 mm

# 877H WHEEL LOADER



TOUGH WORLD. TOUGH EQUIPMENT.

# 877H SPECIFICATIONS >>>

## ENGINE

Emission Regulation	Tier 2 / Stage II
Make	Cummins
Model	6LTA A8.9
Gross Power	221 kW (300 hp) @ 2,000 rpm
Net Power	210 kW (285 hp) @ 2,000 rpm
Peak Torque	1,487 N · m @ 1,400 rpm
Displacement	8.9 L
Number of Cylinders	6
Aspiration	Turbocharged & Air-to-air intercooled

## TRANSMISSION

Transmission Type	Countershaft, power shift
Torque Converter	Single stage, three elements
Maximum Travel Speed, fwd	38.3 km/h
Maximum Travel Speed, rev	26.8 km/h
Number of Speeds, fwd	4
Number of Speeds, rev	3

## AXLES

Differential Front Type	Limited slip
Differential Rear Type	Limited slip
Axle Oscillation	±12°

## STEERING

Steering Configuration	Articulated
Steering Relief Pressure	20.7 MPa

## BRAKES

Service Brake Type	Wet discs brake
Service Brake Actuation	Hydraulic
Parking Brake Type	Flexible shaft control
Parking Brake Actuation	Hydraulic

## HYDRAULIC SYSTEM

Main Pump Type	Piston + Gear
Main Relief Pressure	20.7 MPa
Raise	5.7 s
Dump Time	1.3 s
Float Down Time	3.3 s
Fastest Total Cycle Time	10.3 s

## LOADER ARM PERFORMANCE

Tipping Load - Straight	18,806 kg
Tipping Load - Full Turn	16,020 kg
Bucket Breakout Force	200 kN
A Maximum Hinge Pin Height	4,355 mm
B Dump Clearance at Full Height Discharge	3,150 mm
C Dump Reach at Full Height Discharge	1,312 mm
D Maximum Digging Depth, Bucket Level	100 mm
S <sub>1</sub> Bucket Rollback at Ground Level	45°
S <sub>2</sub> Bucket Rollback at Carry	49°
S <sub>3</sub> Bucket Rollback at Maximum Height	60°
S <sub>4</sub> Maximum Dump Angle at Full Height	45°

## BUCKET PERFORMANCE

Reference Bucket	3.5 - 7.0 m <sup>3</sup>
------------------	--------------------------

## DIMENSIONS

E Ground Clearance	485 mm
G Wheelbase	3,550 mm
H Cab Height	3,580 mm
J Wheel Tread	2,270 mm
K Width Over Tires	2,970 mm
L Length with Bucket Down	9,100 mm
M Turn Angle, Either Side	38°
P Rear Angle of Departure	26°
R <sub>1</sub> Turning Radius, Bucket Carry	7,470 mm
R <sub>2</sub> Turning Radius, Outside of Tire	6,625 mm

## TIRES

Tire Size	26.5 - 25
-----------	-----------

## OPERATING WEIGHTS

Operating Weight	23,950 kg
------------------	-----------

## SERVICE CAPACITIES

Fuel Tank	420 L
Engine Oil	30 L
Cooling System	36 L
Hydraulic Reservoir	220 L
Transmission and Torque Converter	50 L
Axles, each	60 L

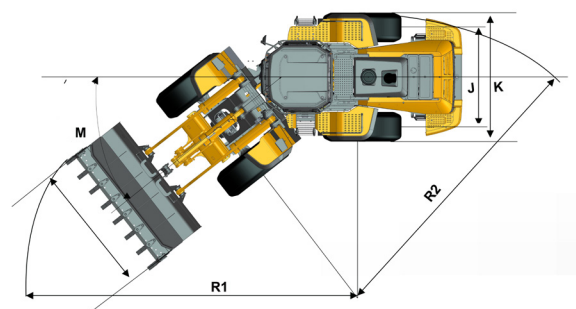
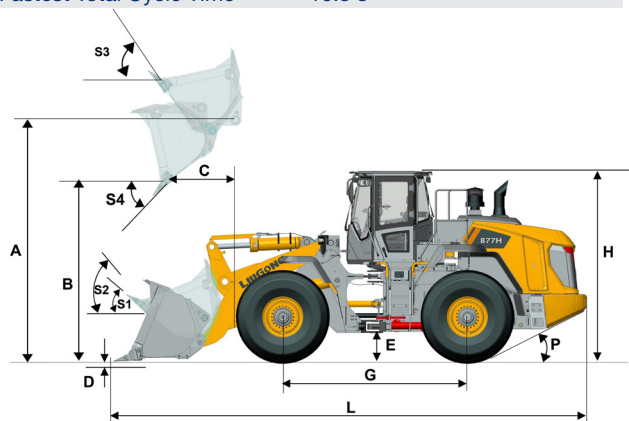

Guangxi Liugong Machinery Co., Ltd.

No. 1 Liutai Road, Liuzhou, Guangxi 545007, PR China  
 T: +86 772 3886124 E: overseas@liugong.com  
 www.liugong.com

12/2016 Designed by LiuGong

Specifications and designs are subject to change without notice. Machines shown may include optional equipment.